

Tech Sheet: Stemme S-10 & S-12

(stemme-STE.pdf)



Stemme S-12 Canopy/Nose Cover

Section 1: Glider Canopy/Cockpit/Fuselage Covers

Turtledeck Extension adds more cover material to the aft edge of the Canopy/Nose Cover, providing custom coverage for antennas, solar panels or motorglider bay doors.

This cover type is made from Silver Acrylic Sunbrella canvas and is 100% lined with a soft and smooth microfiber. Bruce's Custom Covers developed this material combination especially for aircraft protection. The outer material is medium weight and treated for water resistance, UV resistance and anti-static buildup. The inner lining is a very soft and smooth microfiber to prevent scratching. The material is very reflective, and tests show that the cabin interior temperature can be reduced to near-ambient temperature on the hottest of days. It is water, ice and snow repellent, yet breathable to allow moisture to escape from between the cover and the aircraft surface.

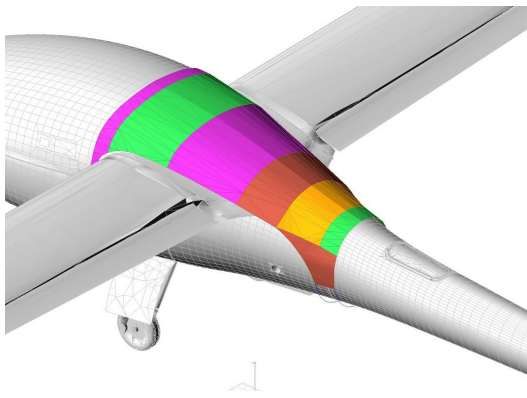

Stemme S-10 & S-12 Turtledeck Cover, 3D model

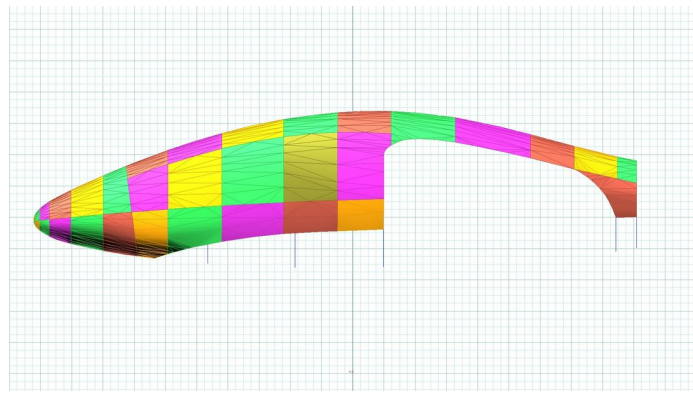

Stemme S-12 Canopy/Nose Cover with Turtledeck Extension, 3D model

Description	Part Number	Price
COCKPIT/NOSE COVER	STE-000	\$630.00
EXTENDED COCKPIT/NOSE COVER	STE-005	\$715.00
TURTLEDECK EXT, antennas, solar panels, motor bay	STE-095	\$95.00

Section 2: Engine Covers



FOR INTERIOR USE. Cub Crafters CC-11 Insulated Hangar Blanket, available in Red or Silver



FOR INTERIOR USE. Cub Crafters CC-11 Insulated Hangar Blanket, available in Red or Silver

Description	Part Number	Price
INSULATED HANGAR BLANKET, INTERIOR USE	STE-HB1	\$300.00

Section 4: Glider Wing/Tail/Empennage Covers

All Weather Wing Covers are a perfect solution to protect your paint from sun damage and prevent winter frost, snow, ice buildup, and corrosion. They are made from Solution-Dyed Polyester or Acrylic *Sunbrella* and form-fit to slip around each wing tip, cover the entire upper surface of the wing and wrap around the leading and trailing edges. The covers secure under the wing with adjustable straps from the trailing edge to the leading edge. The wing covers can also attach to each other with adjustable straps at the leading and trailing edges of the wing under the belly of the plane. Wing covers are labeled LEFT and RIGHT for installation convenience. Wing Covers are available for travel use or long-term, all year use.

ALL-YEAR USE MATERIAL - Made with Silver Acrylic Sunbrella canvas, the all-year use material is the best option for sun protection and cover longevity. This heavier more durable material is intended for all weather conditions, such as rain and snow or lots of sun.

WINTER USE MATERIAL - Made with Solution-Dyed Polyester fabric, this option is intended for seasonal use to aid in deicing, rain mitigation, or for occasional travel. The material is lighter and more compact, but more susceptible to UV damage and may have a shorter useful life if used continuously outside than the all-year use material.

All Weather Horizontal Stabilizer Covers are a perfect solution to protect your paint from sun damage and prevent frost, snow, ice buildup, and corrosion. They are made from Solution-Dyed Polyester or Acrylic *Sunbrella*. They cover the entire upper surface of the stabilizers and overlap around the leading and trailing edges as well as the wing tip. The covers secure under each stabilizer with adjustable straps. In some instances, cut-outs are made in the trailing edge of the wing covers to accommodate static wicks. Horizontal Stabilizer Covers are available for winter use or long-term all year use, and are normally made from Solution-Dyed Polyester or Acrylic *Sunbrella*. A Hail Protection version can be made which incorporates dense closed cell foam into the entire upper surface of the wing covers to help prevent hail damage. Although these covers are bulky, they do help protect your wing and control surfaces against small to medium-size hail.

ALL-YEAR USE MATERIAL - Made with Silver Acrylic Sunbrella canvas, the all-year use material is the best option for sun protection and cover longevity. This heavier more durable material is intended for all weather conditions, such as rain and snow or lots of sun.

WINTER USE MATERIAL - Made with Solution-Dyed Polyester fabric, this option is intended for seasonal use to aid in deicing, rain mitigation, or for occasional travel. The material is lighter and more compact, but more susceptible to UV damage and may have a shorter useful life if used continuously outside than the all-year use material.

The **Stemme S-10 & S-12 Empennage Cover** is a complete, one-piece cover which covers both the vertical and horizontal stabilizers, as well as the tailboom. It is normally made from *Solution-Dyed Polyester* or *Acrylic Sunbrella*. The cover attaches with adjustable straps underneath the belly. The cover is pulled back over the vertical stabilizer and a plastic all-weather zipper is closed at the trailing edge of the rudder. The cover is then stretched over the elevators and zippered closed along the bottom outboard elevator surfaces. The covers cinch under the horizontal stabilizers using adjustable straps. All antennas, beacons and static wicks, if applicable, are accounted for in the design.

ALL-YEAR USE MATERIAL - Made with Silver Acrylic Sunbrella canvas, the all-year use material is the best option for sun protection and cover longevity. This heavier more durable material is intended for all weather conditions, such as rain and snow or lots of sun.

WINTER USE MATERIAL - Made with Solution-Dyed Polyester fabric, this option is intended for seasonal use to aid in deicing, rain mitigation, or for occasional travel. The material is lighter and more compact, but more susceptible to UV damage and may have a shorter useful life if used continuously outside than the all-year use material.



STEMME S10-VT WING FOLD COVERS



Stemme S-12 Wing Covers, Spandex Type

Description	Part Number	Price
WING FOLD COVERS (set of 4)	STE-200	\$305.00

WING COVERS (encloses top, bottom (partial) & open wing joints), WINTER USE (set of 4)	STE-210	\$1455.00
WING COVERS (encloses top, bottom (partial) & open wing joints), ALL YEAR USE (set of 4)	STE-215	\$2000.00
WING COVERS (Spandex, fully enclosed, padded leading edge) (set of 4)	STE-220	\$2475.00
HORIZONTAL STABILIZER COVERS, WINTER USE (set of 2)	STE-300	\$295.00
HORIZONTAL STABILIZER COVERS, ALL YEAR USE (set of 2)	STE-305	\$345.00
EMPENNAGE COVER, ALL YEAR USE (includes horiz. stab cover) (set of 2)	STE-405	\$985.00

Section 7: Light Weight Products: Travel Covers and FlyAway Covers

The **Lightweight Travel Canopy/Nose Cover** will cover the same area as our standard canopy/nose cover, but the material used is very lightweight and will fold up and store in a much smaller space. This cover is ideal for the airplane that is mostly in a hangar or in storage and only needs a cover on rare occasions.

Travel Covers are made with Silver Solution-Dyed Polyester fabric and only lined over the windshield to save weight. The material is lightweight and more compact for easy stowage in the aircraft. The polyester material is water resistant, but only intended for occasional use outside. We also have an ultra lightweight material available for fitted hangar dust covers. For daily outdoor use, the non-travel Sunbrella Cover is the best choice.

Description	Part Number	Price
TRAVEL COVER, Light Weight Travel Canopy/Nose Cover	STE-800	\$505.00

Section 10: Inside the Hangar

Designed to prevent damage to the wingtip in crowded hangars or high traffic areas, these products are made of bright red Naugahyde and thickly padded with a sandwich of closed cell foam. Protects delicate winglets, casters and their housings, and soft finishes.



Schempp-Hirth Ventus-2B winglet/wingtip pads



Schempp-Hirth Ventus-2B winglet/wingtip pads

Description	Part Number	Price
WINGTIP PADS (set of 2)	STE-280	\$255.00

Prices subject to change. Other Covers and Design Alterations: Prices on request.
Prices are FOB Morgan Hill, CA. Sales tax on orders shipped to California addresses. Orders take approximately 3 weeks to complete. For domestic orders we normally ship by UPS ground service. Next day shipping and air parcel post is available on request. We can take payment by Visa, Mastercard, American Express, or Discover.

Bruce's Custom Covers offers protective covers and plugs for virtually every type of airplane, jet and helicopter. If you have questions about our products please call any time TOLL FREE: 800/777-6405, or FAX: 408/738-2729.

Instructions: Measure to the nearest 1/8" and only fill in what applies. You may email, fax or phone in the measurements.

Aircraft Reg / Tail Number: _____ Aircraft Type: _____ Year: _____
 Name: _____ Phone & Email: _____

Propellor Measurements

Please check one:	2 - Blade	3 - Blade	4 - Blade
A Measure along surface of cone			
B Measure "straight line" base to tip			
C Base to top of blade root opening			
D Provide diameter or circumference			
E Provide diameter or circumference			
F Blade root to prop tip			
G Trailing edge to leading edge			
H Trailing edge to leading edge			
J Trailing edge to leading edge			

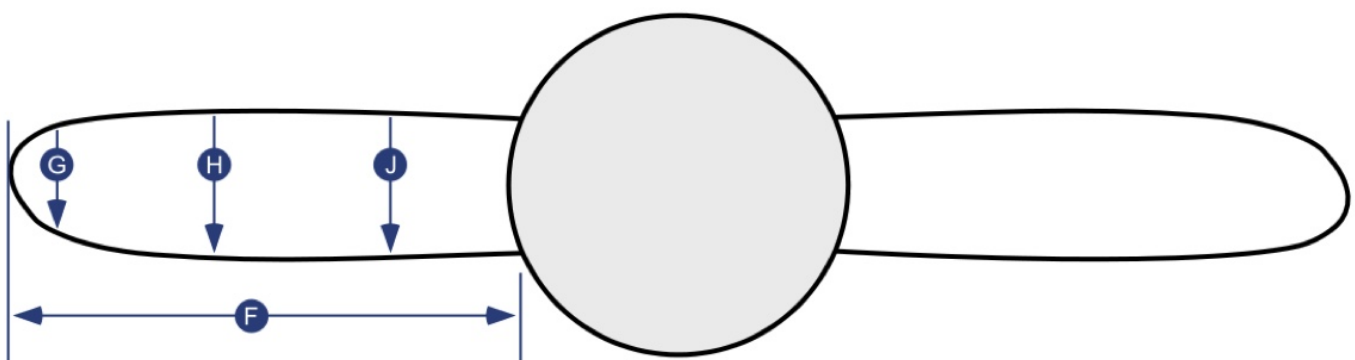
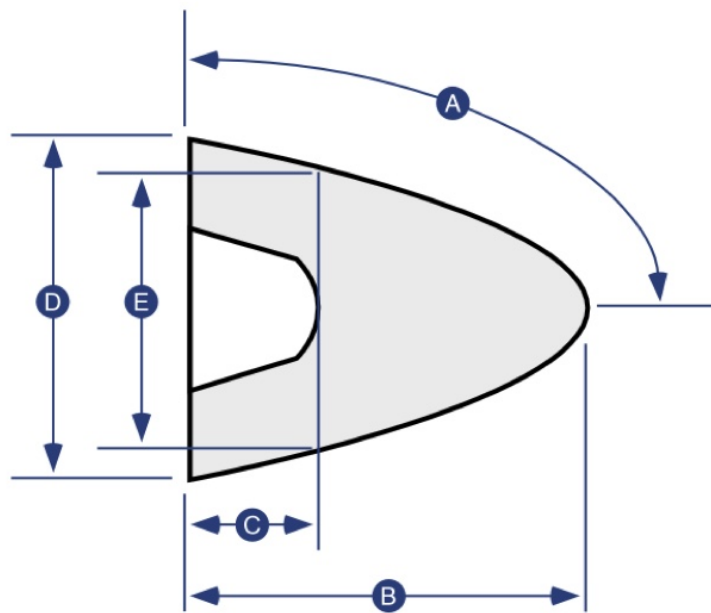
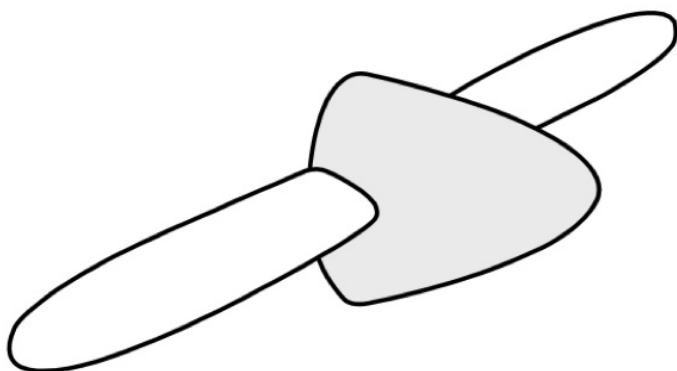

Instructions: Measure to the nearest 1/8" and only fill in what applies. You may email, fax or phone in the measurements.

Aircraft Reg / Tail Number: _____ Aircraft Type: _____ Year: _____
 Name: _____ Phone & Email: _____

OAT Placement	
A	From top of windshield
B	Offset from centerline
	Left Center Right <i>(pilot) (co-pilot)</i>
C	Height
D	From FWD edge
E	From lower edge
F	From forward corner
G	Distance forward



Antenna Placements	Example <i>(inches or metric)</i>	Antenna #1			Antenna #2			Antenna #3			Antenna #4		
H Distance from top center windshield to front of Antenna	34 5/8"												
J Length/Width of Antenna base	5 1/2" x 3 1/4"												
K Offset from Centerline	9 1/2"												
Antenna Offset (mark one)	Left Center Right <i>(pilot) X (co-pilot)</i>	Left Center Right <i>(pilot) (co-pilot)</i>	Left Center Right <i>(pilot) (co-pilot)</i>	Left Center Right <i>(pilot) (co-pilot)</i>	Left Center Right <i>(pilot) (co-pilot)</i>	Left Center Right <i>(pilot) (co-pilot)</i>	Left Center Right <i>(pilot) (co-pilot)</i>	Left Center Right <i>(pilot) (co-pilot)</i>	Left Center Right <i>(pilot) (co-pilot)</i>	Left Center Right <i>(pilot) (co-pilot)</i>	Left Center Right <i>(pilot) (co-pilot)</i>	Left Center Right <i>(pilot) (co-pilot)</i>	
L Slope length of Antenna (types 1-3 only)	18"												
M Antenna Type (see types below)	1												



Ph: 408/738-3959 • Toll Free: 800/777-6405 • Fax: 408/738-2729 • bruce@aircraftcovers.com