

Tech Sheet: McDonnell Douglas Globemaster C-17

(mcdonnell-douglas-C17.pdf)



McDonnell Douglas C-17 Intake Cover

Section 2: Engine Covers

The **McDonnell Douglas Globemaster C-17 Intake Covers** are designed to install easily yet be completely storable. A spring steel hoop is sewn into the hem of each cover, allowing them to be installed without climbing onto the wing or using a stepladder. To store the covers the spring steel hoop folds like a band-saw blade into three nesting rings. Each cover folds into a compact circular bundle which is stored in the included duffle bag, yet they unfold quickly for use. The Tri-Fold Ring cover is made of medium weight nylon which is available in a variety of colors to match the paint trim. Each cover set comes complete with installation and folding instructions. The aircraft's registration number can be silkscreened onto the cover for an extra charge.

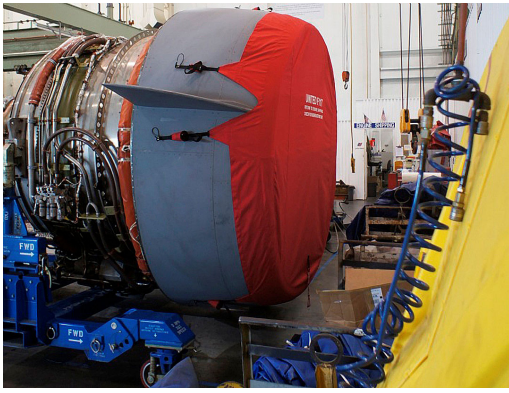

C-17 F117 Intake Cover (OEM Design)



C-17 Engine Intake Cover with Custom Artwork

Description	Part Number	Price
INTAKE COVERS, OEM Type (pin type) (set of 4)	C17-100	Contact Us
INTAKE COVER, OEM Type, 1 each	C17-105	Contact Us
EXHAUST COVERS, Equivalent or Better to NSN 1730-01-358-0936, MD P/N: 17G110001-1 (set of 4)	C17-305	Contact Us

Section 3: Plugs & Protection

McDonnell Douglas Globemaster C-17 Heat Resistant Pitot Tube Covers are made of Naugahyde vinyl, and lined with a non-burning material. They are designed to cover the entire pitot assembly, slipping over the tube and tightening around the base with a Velcro strap detail. A "Remove Before Flight" streamer is attached to the cover. **Heat Resistant Pitot Covers** are an upgrade to our standard design, and help prevent the pitot cover from melting onto the tube if the pitot heat is accidentally turned on while installed. If you want the set tethered together, please let us know.

The **Engine Inlet Plugs** are custom fit for your McDonnell Douglas Globemaster C-17 intakes, made with heavy-duty vinyl material, and stuffed with a single block of sculpted urethane foam. Each plug has a zipper that allows the foam to be removed and dried if necessary. Engine plugs have 'remove before flight' streamers sewn onto the face of the plugs. Most plugs are imprinted with the aircraft registration number in black for an extra charge. Storage bag NOT included. Engine plugs may be inserted after flight when the engine is still warm. Engine Inlet Plugs are commonly referred to as Cowl Plugs, Intake Plugs, Cowl Blocks, Engine Blocks, and Engine Bunges.



C-17 Bypass and Exhaust Plugs (illustration)

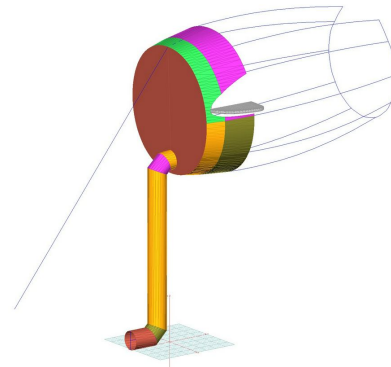

Lockheed C-17 Intake Cover with Preheater Hose, 3D model

Description	Part Number	Price
INTAKE PLUGS, framed, Bi-fold design (set of 4)	C17-130	Contact Us

BYPASS VENT & EXHAUST PLUGS, donut ring folding type (set of 12)	C17-200	Contact Us
EXHAUST PLUGS (set of 4)	C17-201	Contact Us
BYPASS VENT PLUGS (set of 8)	C17-202	Contact Us
BYPASS VENT PLUGS, Per Engine (set of 2)	C17-203	Contact Us
PITOT COVERS, heat resistant type (set of 4)	C17-400	Contact Us

Section 5: HeatShields & Sun Reflectors

Cockpit Heatshields are interior sunshades for the aircraft's cockpit. The product is a unique composite of closed-cell foam with a silver mylar finish. The semi-rigid design is stiff enough to stand inside the window framing. The set folds up flat and is easily stored in the included storage sleeve. Some designs may require velcro and suction cups. Our Heatshields for jets are offered white side out because some aircraft manufacturers have issued advisories against reflective window inserts due to potential heat damage. A Heatshield is an excellent short-term remedy for cockpit overheating, but an external fabric cover is more effective for long-term protection.

Description	Part Number	Price
COCKPIT HEATSHIELDS (set of 8)	C17-900	Contact Us

Section 6: Miscellaneous Products

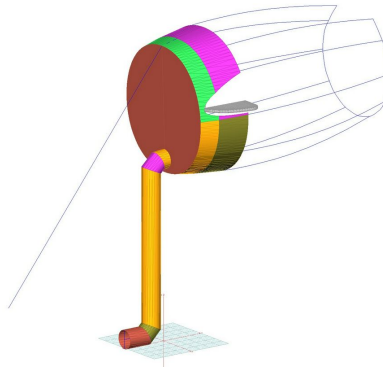

Lockheed C-17 Intake Cover with Preheater Hose, 3D model

Description	Part Number	Price
STORAGE BAG (individual bags for each engine set) (set of 4)	C17-120	Contact Us
MAINTENANCE THRUST REVERSER COVER (Mounted on Test Stand), fully enclosed	C17-160	Contact Us
CENTER CONSOLE/THROTTLE QUADRANT COVER (padded)	C17-700	Contact Us

Section 7: Light Weight Products: Travel Covers and FlyAway Covers

The **McDonnell Douglas Globemaster C-17 Intake Covers** are designed to install easily yet be completely storable. A spring steel hoop is sewn into the hem of each cover, allowing them to be installed without climbing onto the wing or using a stepladder. To store the covers the spring steel hoop folds like a band-saw blade into three nesting rings. Each cover folds into a compact circular bundle which is stored in the included duffel bag, yet they unfold quickly for use. The Tri-Fold Ring cover is made of medium weight nylon which is available in a variety of colors to match the paint trim. Each cover set comes complete with installation and folding

instructions. The aircraft's registration number can be silkscreened onto the cover for an extra charge.

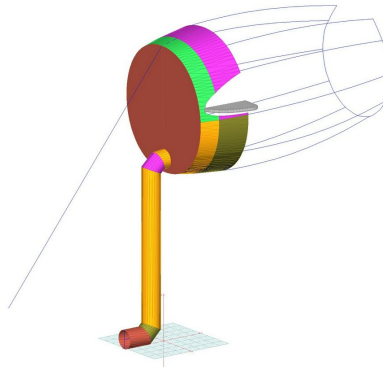

Lockheed C-17 Intake Cover with Preheater Hose, 3D model

Description	Part Number	Price
INTAKE COVERS, light weight travel type (30 Lbs In Storage Bag) (set of 4)	C17-110	Contact Us

Prices subject to change. Other Covers and Design Alterations: Prices on request.
Prices are FOB Morgan Hill, CA. Sales tax on orders shipped to California addresses. Orders take approximately 3 weeks to complete. For domestic orders we normally ship by UPS ground service. Next day shipping and air parcel post is available on request. We can take payment by Visa, Mastercard, American Express, or Discover.

Bruce's Custom Covers offers protective covers and plugs for virtually every type of airplane, jet and helicopter. If you have questions about our products please call any time TOLL FREE: 800/777-6405, or FAX: 408/738-2729.



A division of Aircraft Covers, Inc.

18850 Adams Ct.
Morgan Hill, CA 95037
www.AircraftCovers.com

Aircraft Cover Ordering Form

Customer Info	Name _____ Shipping Address _____ _____ Phone & Email _____
Payment	Credit Card Number <input type="text"/> <input type="text"/> <input type="text"/> <input type="text"/> <input type="text"/> <input type="text"/> <input type="text"/> <input type="text"/> <input type="text"/> <input type="text"/> <input type="text"/> <input type="text"/> <input type="text"/> <input type="text"/> <input type="text"/> <input type="text"/> <input type="text"/> Exp. Date <input type="text"/> <input type="text"/> / <input type="text"/> <input type="text"/> V-Code* <input type="text"/> <input type="text"/> <input type="text"/> <input type="text"/> <small>*Visa, Mastercard, Discover: last 3 numbers on back of card, right of signature. Amex: 4 smaller numbers printed on face of card.</small>
A/C Info	Reg / Tail Number: _____ Aircraft Type: _____ Year: _____ Colors / Paint Scheme (be specific): _____

Please specify below the items you would like to order.
See technical sheet or visit our website for part numbers (or just fill in the description)

	Part Number	Quant	Description	Price
1				
2				
3				
4				
5				
6				
7				
8				
9				
10				

Optional Items (check the box of the item you want)

Imprint aircraft registration number onto both sides of canopy cover.....\$35.00

Imprint aircraft registration number onto jet intake covers.....\$55.00

TOTAL

Ph: 408/738-3959 • Toll Free: 800/777-6405 • Fax: 408/738-2729 • bruce@aircraftcovers.com