

Tech Sheet: Bell AH-1 Cobra (all models)

(bell-209.pdf)

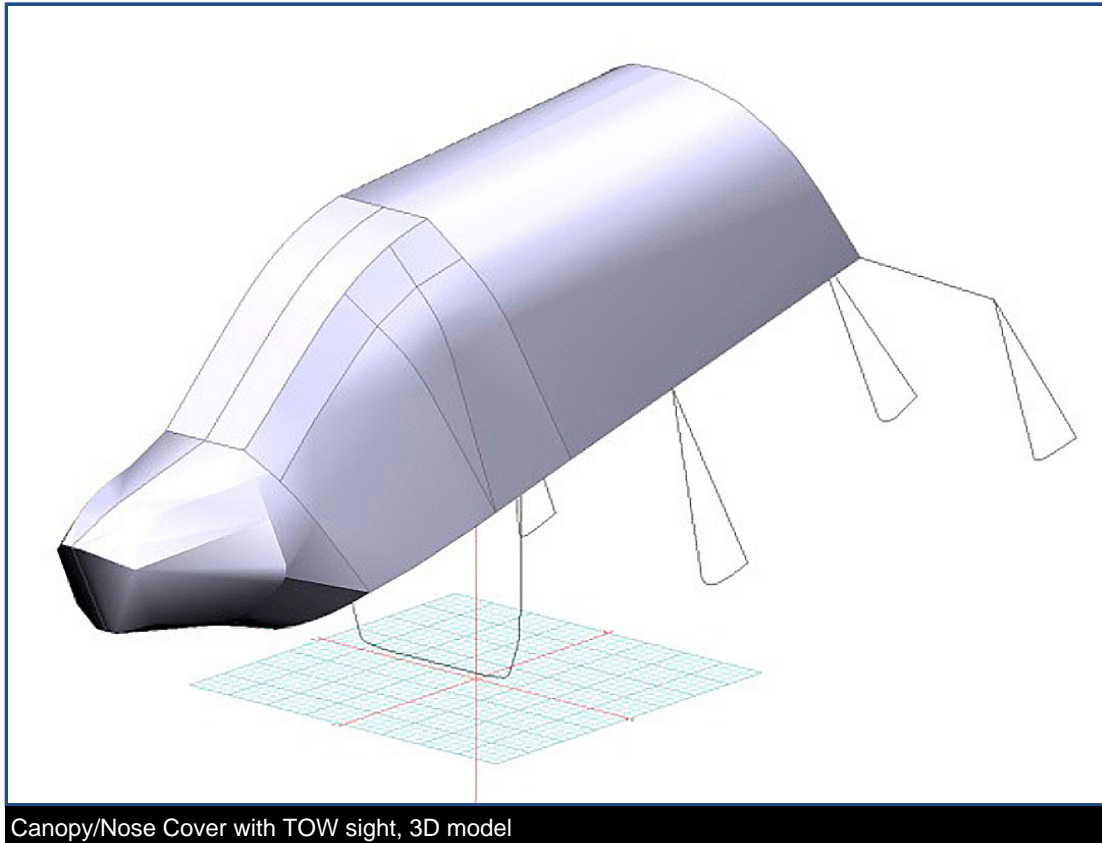

Canopy/Nose Cover with TOW sight, 3D model

Section 1: Cockpit/Bubble Covers

The **Bell AH-1 Cobra (all models) Canopy/Nose Cover** helps reduce damage to the upholstery and avionics caused by excessive heat and can eliminate problems caused by leaking door and window seals. They keep the windshield and window surfaces clean and help prevent vandalism and theft.

Canopy/Nose Covers enclose the entire canopy including the windshield, skylights, and chin bubble. Attachment buckles are made of nonmetal *Delrin*, designed for rugged outdoor use. Both the top and bottom hems of the cover have a special rope-hem feature with which they can be tightened to help prevent abrasive chafing of the windshield. Pockets are sewn into the cover for the temperature probe and pitot tubes. The bubble cover is reinforced with patches at hinge points, door handles, and for the windshield wipers. For ease of installation, the bubble cover is color-coded (red=left, green=right) with color swatches sewn into the corners. This cover type is made from Silver Acrylic Sunbrella canvas and is 100% lined with a soft and smooth microfiber. Bruce's Custom Covers developed this material combination especially for aircraft protection. The outer material is medium weight and treated for water resistance, UV resistance and anti-static buildup. The inner lining is a very soft and smooth microfiber to prevent scratching. The material is very reflective, and tests show that the cabin interior temperature can be reduced to near-ambient temperature on the hottest of days. It is water, ice and snow repellent, yet breathable to allow moisture to escape from between the cover and the aircraft surface.

The **Bell AH-1 Cobra (all models) Bubble Cover** helps reduce damage to the upholstery and avionics caused by excessive heat and can eliminate problems caused by leaking door and window seals. They keep the windshield and window surfaces clean and help prevent vandalism and theft.

The **Bubble Cover** encloses the entire canopy including the windshield, skylights, and chin bubble Attachment buckles are made of nonmetal *Delrin*, designed for rugged outdoor use. Both the top and bottom hems of the cover have a special rope-hem feature with which they can be tightened to help prevent abrasive chafing of the windshield. Pockets are sewn into the cover for the temperature probe and pitot tubes. The bubble cover is reinforced with patches at hinge points, door handles, and for the windshield wipers. For ease of installation, the bubble cover is color-coded (red=left, green=right) with color swatches sewn into the corners.

This cover type is made from Silver Acrylic Sunbrella canvas and is 100% lined with a soft and smooth microfiber. Bruce's Custom Covers developed this material combination especially for aircraft protection. The outer material is medium weight and treated for water resistance, UV resistance and anti-static buildup. The inner lining is a very soft and smooth microfiber to prevent scratching. The material is very reflective, and tests show that the cabin interior temperature can be reduced to near-ambient temperature on the hottest of days. It is water, ice and snow repellent, yet breathable to allow moisture to escape from between the cover and the aircraft surface.



Canopy/Nose Cover, covers canopy glass and TADS

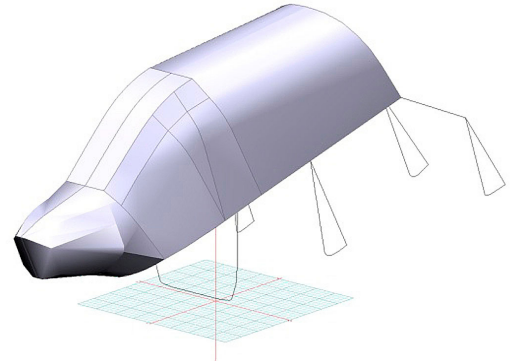

Canopy/Nose Cover with TOW sight, 3D model

Description	Part Number	Price
CANOPY/NOSE COVER (WITH TOW SIGHT)	209-000	Contact Us
CANOPY/NOSE COVER (AH-1J)	209-010	Contact Us
CANOPY COVER	209-015	Contact Us

Section 2: Engine/Tail Rotor Covers

The **Bell AH-1 Cobra (all models) Blade Covers** are sewn of medium weight Solution-Dyed Polyester. Cut "full" to avoid trim tabs, Blade Covers can be installed from the ground with the aid of lightweight rope which is attached to the open end. Covers are cinched tight at the blade root with straps and quick-release plastic buckles. A small opening at the tip of the cover allows for some air circulation and drainage. For operations in extremely cold weather, the **Cold Weather Blade Covers** are fitted with full length zippers, and with optional "boots" designed to accept a preheater hose.

ALL-YEAR USE MATERIAL - Made with Silver Acrylic Sunbrella canvas, the all-year use material is the best option for sun protection and cover longevity. This heavier more durable material is intended for all weather conditions, such as rain and snow or lots of sun.

WINTER USE MATERIAL - Made with Solution-Dyed Polyester fabric, this option is intended for seasonal use to aid in deicing, rain mitigation, or for occasional travel. The material is lighter and more compact, but more susceptible to UV damage and may have a shorter useful life if used continuously outside than the all-year use material.

Rotor Hub Covers overlaps with the Blade Covers to ensure complete protection for the entire main rotor system. Designed like a jacket with sleeves and no collar, the rotor hub cover fastens together below each blade with *Delrin* buckles. The Rotor Hub Cover is normally made from Solution-Dyed Polyester.

The **Bell AH-1 Cobra (all models) Tail Rotor Cover** is a one-piece design which encloses both the blades and their hub,

snapping closed along the bottom edge. The tail rotor cover is normally made from Solution-Dyed Polyester.

ALL-YEAR USE MATERIAL - Made with Silver Acrylic Sunbrella canvas, the all-year use material is the best option for sun protection and cover longevity. This heavier more durable material is intended for all weather conditions, such as rain and snow or lots of sun.

WINTER USE MATERIAL - Made with Solution-Dyed Polyester fabric, this option is intended for seasonal use to aid in deicing, rain mitigation, or for occasional travel. The material is lighter and more compact, but more susceptible to UV damage and may have a shorter useful life if used continuously outside than the all-year use material.

Blade Tie-Downs are "socks" which fit over the blade tip with or without Blade Covers installed. Front blade tie-downs have two lengths of rope or strap which attaches to the front cross tubes on either side of the cabin. The other tie-downs have generous lengths of rope or strap to tie the blades down at any convenient spot.

ALL-YEAR USE MATERIAL - Made with Silver Acrylic Sunbrella canvas, the all-year use material is the best option for sun protection and cover longevity. This heavier more durable material is intended for all weather conditions, such as rain and snow or lots of sun.

WINTER USE MATERIAL - Made with Solution-Dyed Polyester fabric, this option is intended for seasonal use to aid in deicing, rain mitigation, or for occasional travel. The material is lighter and more compact, but more susceptible to UV damage and may have a shorter useful life if used continuously outside than the all-year use material.

Description	Part Number	Price
BLADE COVERS (set of 2)	209-200	Contact Us
BLADE COVERS (COLD WEATHER TYPE) (set of 2)	209-210	Contact Us
MAIN ROTOR COVER	209-300	Contact Us
TAIL ROTOR COVER	209-400	Contact Us
BLADE TIE-DOWNS (fabric type) (set of 2)	209-500	Contact Us
EXHAUST COVER	209-600	Contact Us

Section 3: Plugs & Protection

The **Engine Inlet Plugs** are custom fit for your Bell AH-1 Cobra (all models) intakes, made with heavy-duty vinyl material, and stuffed with a single block of sculpted urethane foam. Each plug has a zipper that allows the foam to be removed and dried if necessary. Engine plugs have 'Remove Before Flight' streamers sewn onto the face of the plugs. Most plugs are imprinted with the aircraft registration number in black for an extra charge. Storage bag NOT included. Engine plugs may be inserted after flight when the engine is still warm. Engine Inlet Plugs are commonly referred to as Cowl Plugs, Intake Plugs, Cowl Blocks, Engine Blocks, and Engine Bungs.

Description	Part Number	Price
ENGINE INLET PLUGS (set of 2)	209-100	Contact Us

Section 7: Light Weight Products: Travel Covers and FlyAway Covers

The **Bell AH-1 Cobra (all models) Lightweight Travel Canopy/Nose Cover** is the same design as our standard bubble cover, but the material used is very lightweight and will fold up and store in a smaller space.

Travel Covers are made with Silver Solution-Dyed Polyester fabric and fully lined over the entire cover. The material is lightweight and more compact for easy stowage in the aircraft. The polyester material is water resistant, but only intended for occasional use outside. We also have an ultra lightweight material available for fitted hangar dust covers. For daily outdoor use, the non-travel Sunbrella Cover is the best choice.

The **Bell AH-1 Cobra (all models) Lightweight Travel Canopy Cover** is the same design as our standard canopy cover, but the material used is very lightweight and will fold up and store in a smaller space.

Travel Covers are made with Silver Solution-Dyed Polyester fabric and fully lined over the entire cover. The material is lightweight and more compact for easy stowage in the aircraft. The polyester material is water resistant, but only intended for occasional use outside. We also have an ultra lightweight material available for fitted hangar dust covers. For daily outdoor use, the non-travel Sunbrella Cover is the best choice.

Description	Part Number	Price
TRAVEL COVER, Light Weight Travel Canopy/Nose Cover (WITH TOW SIGHT)	209-800	Contact Us
TRAVEL COVER, Light Weight Travel Canopy/Nose Cover (AH-1J)	209-810	Contact Us
TRAVEL COVER, Light Weight Canopy Cover	209-820	Contact Us

Prices subject to change. Other Covers and Design Alterations: Prices on request.

Prices are FOB Morgan Hill, CA. Sales tax on orders shipped to California addresses. Orders take approximately 3 weeks to complete. For domestic orders we normally ship by UPS ground service. Next day shipping and air parcel post is available on request. We can take payment by Visa, Mastercard, American Express, or Discover.

Bruce's Custom Covers offers protective covers and plugs for virtually every type of airplane, jet and helicopter. If you have questions about our products please call any time TOLL FREE: 800/777-6405, or FAX: 408/738-2729.

Aircraft Cover Ordering Form

Customer Info	Name _____
	Shipping Address _____ _____
	Phone & Email _____
Payment	Credit Card Number <input type="text"/> <input type="text"/> <input type="text"/> <input type="text"/> <input type="text"/> <input type="text"/> <input type="text"/> <input type="text"/> <input type="text"/> <input type="text"/> <input type="text"/> <input type="text"/> <input type="text"/> <input type="text"/> <input type="text"/> <input type="text"/> <input type="text"/> <input type="text"/>
	Exp. Date <input type="text"/> <input type="text"/> / <input type="text"/> <input type="text"/> V-Code* <input type="text"/> <input type="text"/> <input type="text"/> <input type="text"/>
	<small>*Visa, Mastercard, Discover: last 3 numbers on back of card, right of signature. Amex: 4 smaller numbers printed on face of card.</small>
A/C Info	Reg / Tail Number: _____ Aircraft Type: _____ Year: _____
	Colors / Paint Scheme (be specific): _____

Please specify below the items you would like to order.

See technical sheet or visit our website for part numbers (or just fill in the description)

1	Part Number	Quant	Description	Price
2				
3				
4				
5				
6				
7				
8				
9				
10				

TOTAL

Optional Items (check the box of the item you want)	
<input type="checkbox"/>	Imprint aircraft registration number onto both sides of canopy cover.....\$35.00
<input type="checkbox"/>	Imprint aircraft registration number onto jet intake covers.....\$55.00